

17B0811-5

Приложение №1 к техническому заданию

other $\frac{6.3}{\nabla}$

NO. of Teeth	10
Pitch	152.4
Roller ϕ	41.28

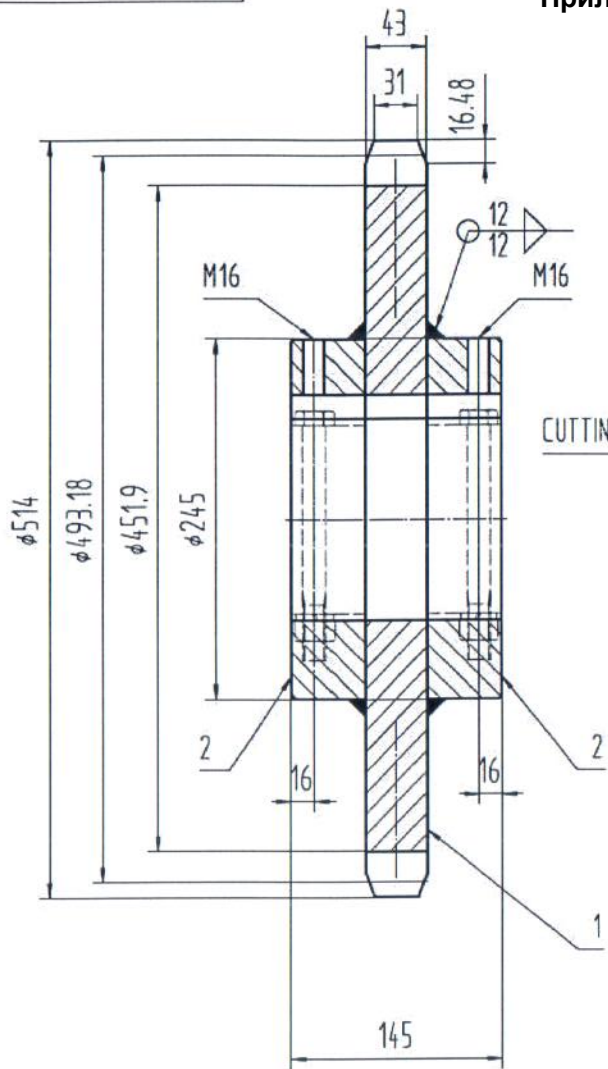

Do not weld in 10mm area as indicated on drawing

CUTTING LINE

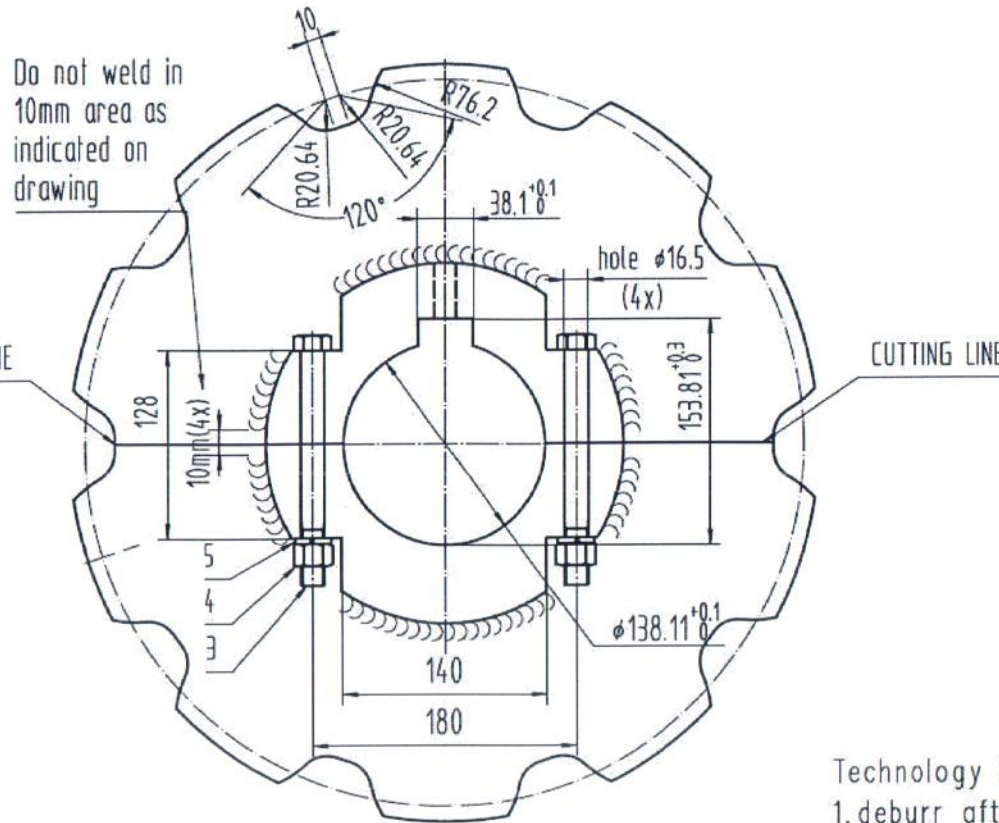

Technology Requests

1. deburr after machine
2. teeth induction hardening HRC45-55
3. clean & oil dip

5	Spring washer 16		4
4	Hex screw set M16		4
3	Hex bolt M16X160 8.8		4
2	HUB	20	2
1	sprocket	45	1

mark	notice	Document updated Nr	signature	date
Drawn by		date	17.8.1	
Checked by		date	17.8.1	
approved by		date	17.8.1	

TEU	4880000237	P=152.4Dr=41.28 Z=10HX138.11
	000.250617.03	
Sprocket		Material: According to the form